



U74AHC1G66

CMOS IC

BILATERAL SWITCH

DESCRIPTION

The U74AHC1G66 is an analog switch which transmits signals from pin(Y or Z) to pin (Z or Y) with an active HIGH enable input pin (E). When pin E is LOW, the switch is turned off.

FEATURES

- * Operation voltage range: 2~5.5V
- * Low power dissipation
- * Very low ON-resistance: 26Ω (typ.) at Vcc=3.0V
16Ω (typ.) at Vcc=4.5V
14Ω (typ.) at Vcc=5.5V

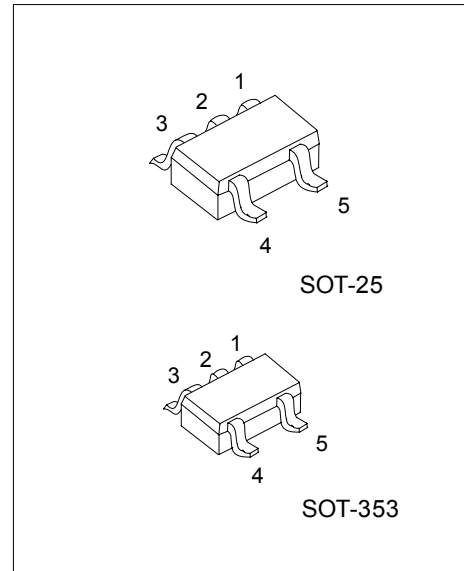

*Pb-free plating product number:
U74AHC1G66L

ORDERING INFORMATION

Order Number		Package	Packing
Normal	Lead Free Plating		
U74AHC1G66-AF5-R	U74AHC1G66L-AF5-R	SOT-25	Tape Reel
U74AHC1G66-AL5-R	U74AHC1G66L-AL5-R	SOT-353	Tape Reel

<p>U74AHC1G66L-AF5-R</p> <p>(1)Packing Type (2)Package Type (3)Lead Plating</p>	<p>(1) R: Tape Reel (2) AF5: SOT-25, AL5: SOT-353 (3) L: Lead Free Plating, Blank: Pb/Sn</p>
---	--

MARKING

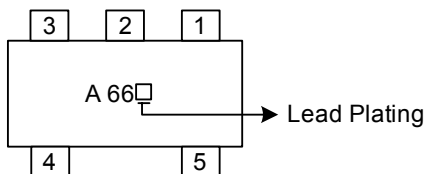

■ PIN CONFIGURATION

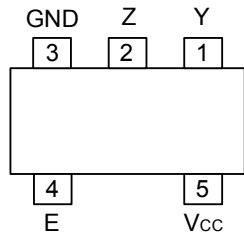

■ PIN DESCRIPTION

PIN NUMBER	SYMBOL	DESCRIPTION
1	Y	independent input/output
2	Z	independent output/input
3	GND	ground
4	E	enable input
5	Vcc	supply voltage

■ FUNCTION TABLE (each gate)

INPUT E	SWITCH
H	ON
L	OFF

■ LOGIC DIAGRAM (positive logic)

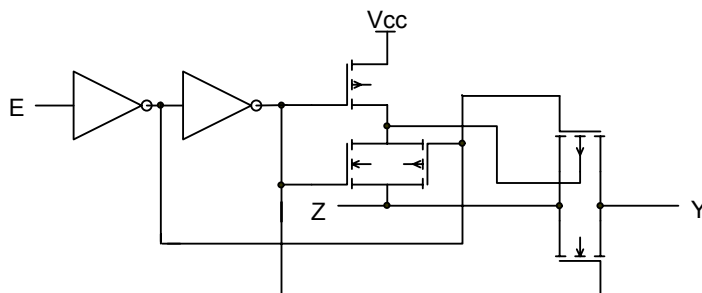
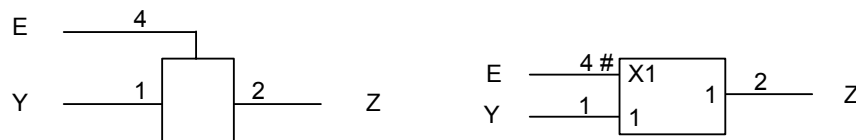

■ ABSOLUTE MAXIMUM RATINGS (unless otherwise specified)(Note 1)

PARAMETER	SYMBOL	RATINGS	UNIT
Supply Voltage	V_{CC}	-0.5~7	V
Enable Input Voltage	V_E	-0.5~7	V
Enable Input Clamp Current	I_{EK}	-20	mA
Switch Diode Current	I_{SK}	± 20	mA
On-State Switch Current(-0.5V<V _{os} <V _{cc} +0.5V)	I_S	± 25	mA
V _{CC} or GND Current	I_{CC}	± 75	mA
Power Dissipation	P_D	250	mW
Storage Temperature	T_{STG}	-65 ~ +150	

Note 1. The input and output voltage ratings may be exceeded if the input and output current ratings are observed.

2. Absolute maximum ratings are those values beyond which the device could be permanently damaged.

Absolute maximum ratings are stress ratings only and functional device operation is not implied.

3. To avoid drawing V_{cc} current out of pin Z, when switch current flows into pin Y, the voltage drop across the bidirectional switch must not exceed 0.4V. If the switch current flows into pin Z, no V_{cc} current will flow out of pin Y. In this case there is no limit for the voltage drop across the switch, but the voltage at pins Y and Z may not exceed V_{cc} or GND.

■ RECOMMENDED OPERATING CONDITIONS

PARAMETER	SYMBOL	CONDITIONS	MIN	TYP	MAX	UNIT
Supply Voltage	V_{CC}		2	5.0	5.5	V
Enable Input Voltage	V_E		0		5.5	V
Switch Voltage	V_S		0		V_{CC}	V
Input Transition Rise or Fall Rate	$\Delta t/\Delta v$	$V_{CC}=3.3+0.3V$			100	ns/V
		$V_{CC}=5.0+0.5V$			20	
Operating Temperature	T_A		-40	25	125	

■ STATIC CHARACTERISTICS

PARAMETER	SYMBOL	TEST CONDITIONS	MIN	TYP	MAX	UNIT	
Input Voltage	High-Level	V_{IH}	$V_{CC}=2.0V$	1.5		V	
			$V_{CC}=3.0V$	2.1			
			$V_{CC}=5.5V$	3.85			
	Low-Level	V_{IL}	$V_{CC}=2.0V$			0.5	V
			$V_{CC}=3.0V$			0.9	
			$V_{CC}=5.5V$			1.65	
Enable Input Leakage Current	$I_{E(LEAK)}$	$V_{CC}=5.5V, V_E=V_{CC}$ or GND			0.1	μA	
State Switch Current	OFF	I_S	$V_{CC}=5.5V, V_S =V_{CC}-GND$			0.1	μA
	ON		$V_{CC}=5.5V$			0.1	μA
ON-Resistance (Peak)	$R_{ON(PEAK)}$ (Note 4)	$V_{CC}=2.0V, V_{IS}=V_{CC}$ to GND, $I_S=1mA$		148		Ω	
		$V_{CC}=3.0V\sim 3.6V, V_{IS}=V_{CC}$ to GND, $I_S=10mA$		28	50		
		$V_{CC}=4.5V\sim 5.5V, V_{IS}=V_{CC}$ to GND, $I_S=10mA$		15	30		
ON-Resistance (Rail)	$R_{ON(RAIL)}$	$V_{CC}=2.0V, V_{IS}=V_{CC}, I_S=1mA$		28		Ω	
		$V_{CC}=2.0V, V_{IS}=GND, I_S=1mA$		30			
		$V_{CC}=3.0V\sim 3.6V, V_{IS}=V_{CC}, I_S=10mA$		18	50	Ω	
		$V_{CC}=3.0V\sim 3.6V, V_{IS}=GND, I_S=10mA$		20	50		
		$V_{CC}=4.5V\sim 5.5V, V_{IS}=V_{CC}, I_S=10mA$		13	22	Ω	
		$V_{CC}=4.5V\sim 5.5V, V_{IS}=GND, I_S=10mA$		15	22		
Quiescent Supply Current	I_Q	$V_{CC}=5.5V, V_E=V_{CC}$ or GND, $V_{IS}=GND$ or $V_{CC}, V_{OS}=V_{CC}$ or GND			1.0	μA	
Enable Input Capacitance	C_E	$V_E=V_{CC}$ or GND		2	10	pF	
Maximum Switch Capacitance	C_S	Independent I/O		4	10	pF	

Note 4. With supply voltages at or near 2V, the analog switch on-state resistance becomes very nonlinear. Only digital signals should be transmitted at these low supply voltages.

■ DYNAMIC CHARACTERISTICS (T_A=25)

Input: t_R, t_F≤3ns; PRR≤1MHz, All typical values are measured at V_{CC}=2V; V_{CC}=3.3V or V_{CC}=5V.

PARAMETER	SYMBOL	TEST CONDITIONS	MIN	TYP	MAX	UNIT
Propagation Delay From Y/Z TO Z/Y	t _{PHL} /t _{PLH}	V _{CC} =2.0V, C _L =50pF		2.2	5	ns
Turn-On Time From E TO Z/Y	t _{PZH} /t _{PZL}	V _{CC} =2.0V, C _L =15pF		7	25	ns
		V _{CC} =2.0V, C _L =50pF		11	35	
Turn-Off Time From E TO Z/Y	t _{PHZ} /t _{PLZ}	V _{CC} =2.0V, C _L =15pF		9	25	ns
		V _{CC} =2.0V, C _L =50pF		13	35	
Propagation Delay From Y/Z TO Z/Y	t _{PHL} /t _{PLH}	V _{CC} =3.0V~3.6V, C _L =50pF		1	2	ns
Turn-On Time From E TO Z/Y	t _{PZH} /t _{PZL}	V _{CC} =3.0V~3.6V, C _L =15pF		4	11	ns
		V _{CC} =3.0V~3.6V, C _L =50pF		5.8	15	
Turn-Off Time From E TO Z/Y	t _{PHZ} /t _{PLZ}	V _{CC} =3.0V~3.6V, C _L =15pF		6	11	ns
		V _{CC} =3.0V~3.6V, C _L =50pF		8.4	15	
Propagation Delay From Y/Z TO Z/Y	t _{PHL} /t _{PLH}	V _{CC} =4.5V~5.5V, C _L =50pF		0.6	1	ns
Turn-On From E TO Z/Y	t _{PZH} /t _{PZL}	V _{CC} =4.5V~5.5V, C _L =15pF		3	8	ns
		V _{CC} =4.5V~5.5V, C _L =50pF		4.4	11	
Turn-Off Time From E TO Z/Y	t _{PHZ} /t _{PLZ}	V _{CC} =4.5V~5.5V, C _L =15pF		5	8	ns
		V _{CC} =4.5V~5.5V, C _L =50pF		6.1	11	

Recommended conditions and typical values. GND=0; t_R=t_F=3ns

PARAMETER	SYMBOL	TEST CONDITIONS	MIN	TYP	MAX	UNIT
Sine-Wave Distortion at f=1kHz		V _{CC} =3.0V~3.6V, V _{IS(P-P)} =2.5V, R _L =10kΩ, C _L =50pF		0.025		%
		V _{CC} =4.5V~5.5V, V _{IS(P-P)} =4.0V, R _L =10kΩ, C _L =50pF		0.015		
Sine-Wave Distortion at f=10kHz		V _{CC} =3.0V~3.6V, V _{IS(P-P)} =2.5V, R _L =10kΩ, C _L =50pF		0.025		%
		V _{CC} =4.5V~5.5V, V _{IS(P-P)} =4.0V, R _L =10kΩ, C _L =50pF		0.015		
Switch OFF Signal Feed-Through (Note 5)		V _{CC} =3.0V~3.6V, R _L =600Ω, C _L =50pF, F=1MHz		-50		dB
		V _{CC} =4.5V~5.5V, R _L =600Ω, C _L =50pF, F=1MHz		-50		
Minimum Frequency Response (-3dB) (Note 6)	f _{MAX}	V _{CC} =3.0V~3.6V, R _L =50Ω, C _L =10pF		230		MHz
		V _{CC} =4.5V~5.5V, R _L =50Ω, C _L =10pF		280		

OPERATING CHARACTERISTICS

Power Dissipation Capacitance	C _{pd}	C _L =50pF, f=10MHz, V _{CC} =5		13		pF
-------------------------------	-----------------	---	--	----	--	----

Note 5. Adjust input voltage V_{IS} is 0dbm level (0dbm=1mW into 600Ω)

6. Adjust input voltage V_{IS} is 0dbm level at V_{OS} for 1MHz (0dbm=1mW into 50Ω)

■ TEST CIRCUIT AND WAVEFORMS

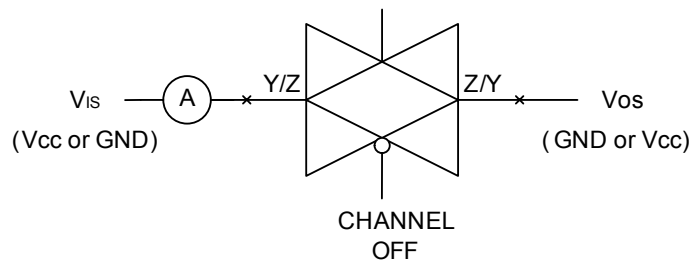

Fig-1 OFF-State Switch Leakage Current Test Circuit

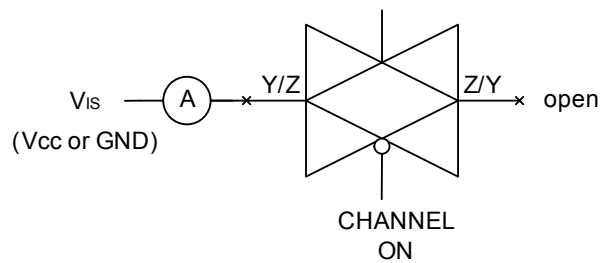

Fig-2 ON-State Leakage Current Test Circuit

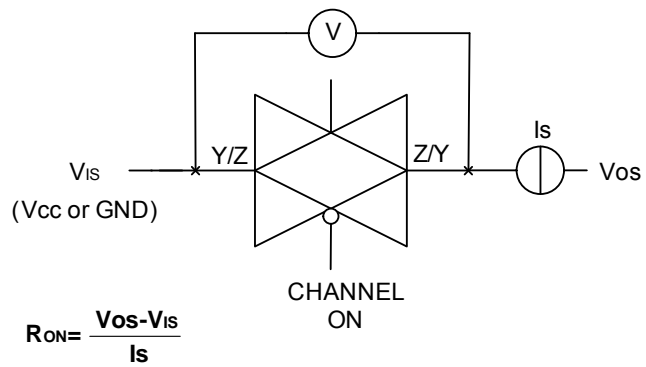

Fig-3 ON-State Resistance Test Circuit

■ TEST CIRCUIT AND WAVEFORMS(Cont.)

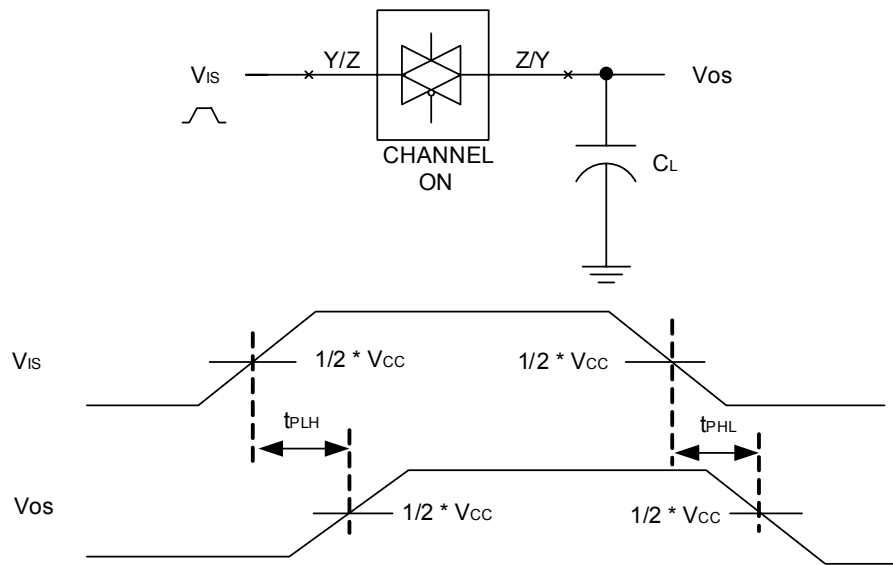

Fig-4 The input (Y/Z) to output (Z/Y) propagation delays.

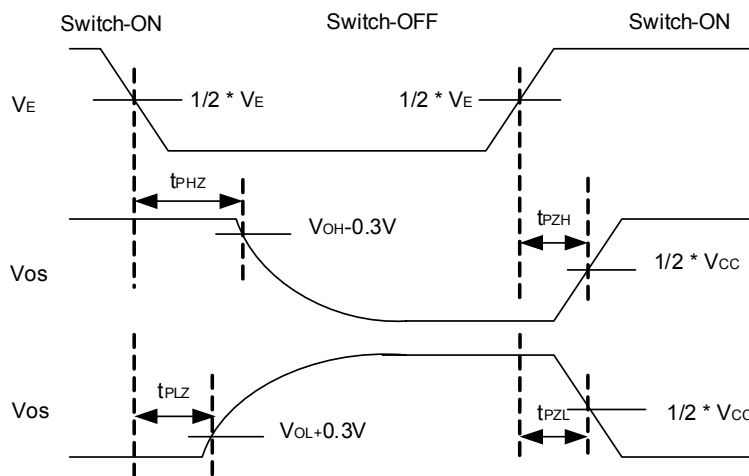
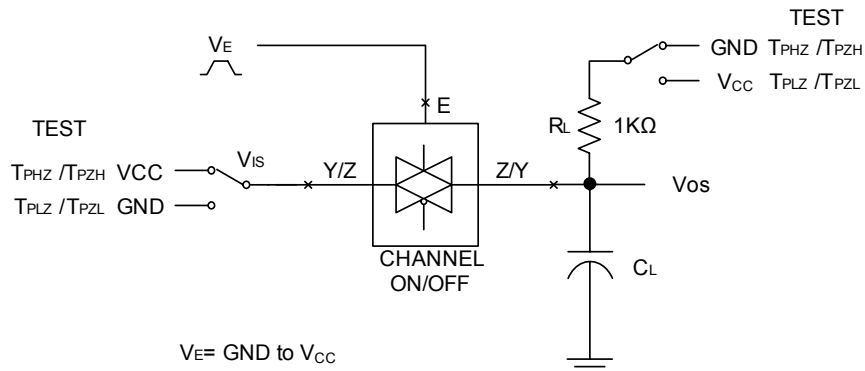

Fig-5 The switch-on and switch-off times.

■ TEST CIRCUIT AND WAVEFORMS(Cont.)

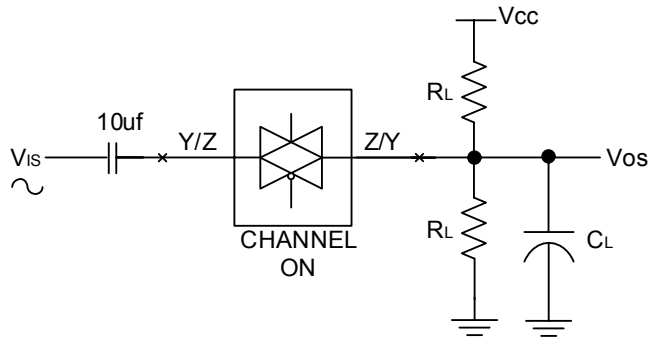

Fig-6 Sine-Wave Distortion

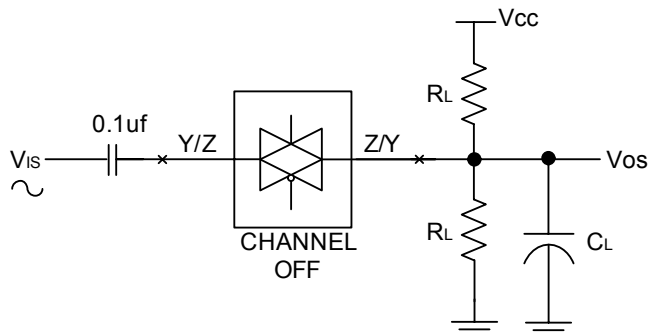

Fig-7 Feed-through Attenuation (Switch OFF)

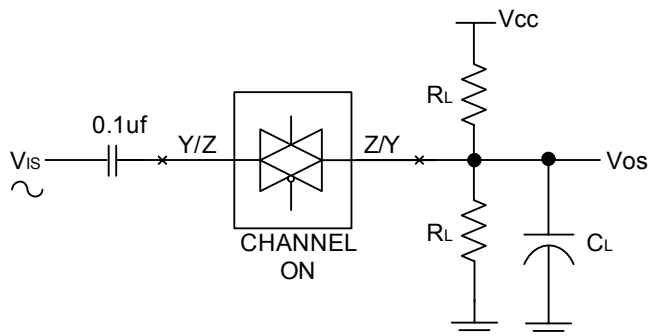

Fig-8 Minimum Frequency Response

UTC assumes no responsibility for equipment failures that result from using products at values that exceed, even momentarily, rated values (such as maximum ratings, operating condition ranges, or other parameters) listed in products specifications of any and all UTC products described or contained herein. UTC products are not designed for use in life support appliances, devices or systems where malfunction of these products can be reasonably expected to result in personal injury. Reproduction in whole or in part is prohibited without the prior written consent of the copyright owner. The information presented in this document does not form part of any quotation or contract, is believed to be accurate and reliable and may be changed without notice.